

EXPERIMENTS

EEE353 Experiment: 1a - EXAMINATION OF DIODE

1. Student Name and Surname:	History:
Res. Asst.:	Note:

List of Materials

- Power Supply (12V)
- Diode (1N4001)
- Lamp (12V)

HOW TO DO THE EXPERIMENT: Make the circuit connections as shown in the Figure.

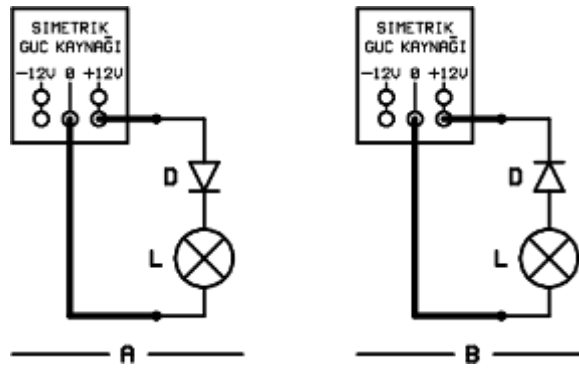

Apply power to the circuit. Answer the questions.

- 1- Is the lamp burnt out? Why?
- 2- Turn off the circuit power. Make the circuit connections as shown in Figure 1B. What was the result? Explain why.
- 3- Item 1 and the results in the item, 2, what should the Anode-Cathode voltages be for the diode to conduct and isolate (**cut off**)?

EEE353 Experiment: 1b DEFINITION OF DIODE CHARACTERISTICS

List of Materials

- Regulated power supply
- Voltage Meter (DC)
- Current Meter (DC)
- Resistance (1 K Ω)
- Diode (1N4001)

HOW TO DO THE EXPERIMENT: Make the circuit connections as shown in the Figure.

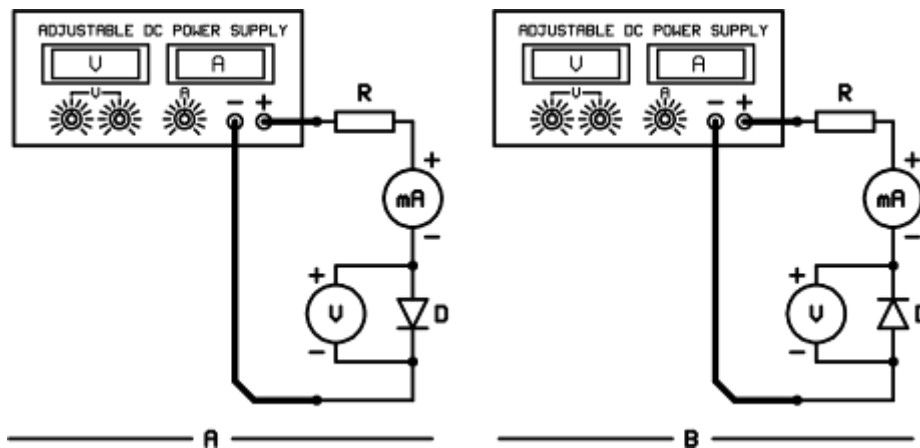

Turn the voltage potentiometers of the regulated power supply to minimum (left). Apply power to the circuit.

Answer the questions.

1- Obtain the current values shown in the table in order by changing the voltage of the regulated power supply. Record the voltage corresponding to each current value on the voltmeter at the diode ends in the table.

Table 1

Order #	I_D (mA)	V_D (V)	$R_D = \frac{V_D}{I_D}$ (Ω)
1	0		
2	0.02		
3	0.05		
4	0.1		
5	0.2		
6	0.5		
7	0.8		
8	1.0		
9	2.0		
10	5.0		

- 2- The obtained I_D and V_D values on the area below and draw the polarization characteristic curve of the diode in the correct direction.

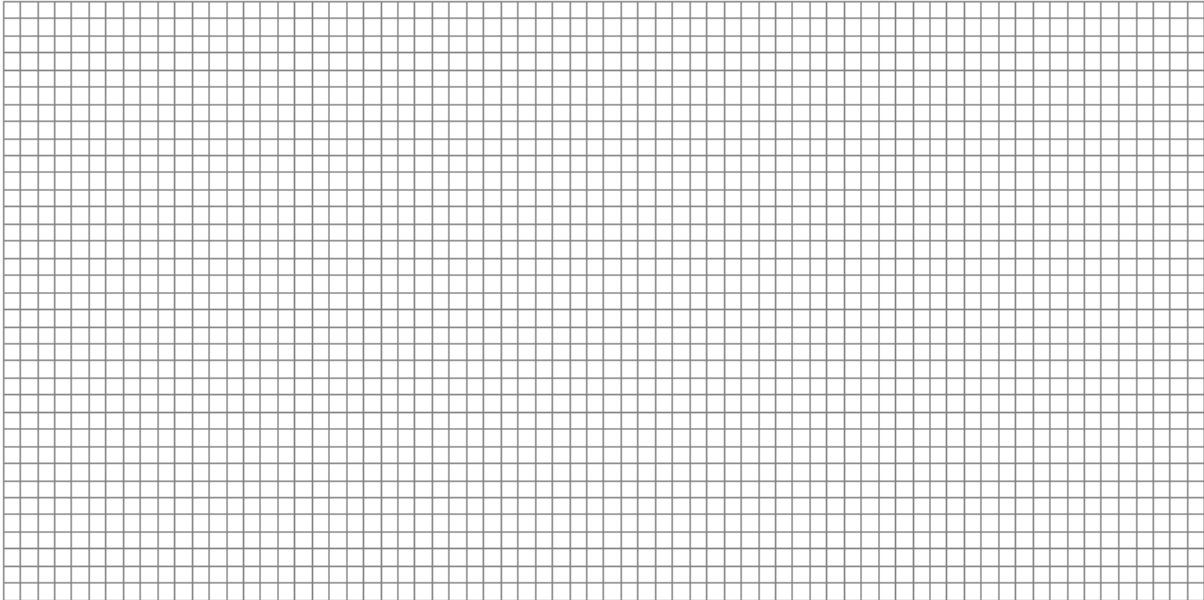

- 3- Turn off the circuit power. Make the circuit connection as in Figure 1B. Apply power to the circuit. In this case, the diode is reverse polarized. This time, obtain the voltage value shown in the table below by adjusting the regulated power supply in order. Record the I_D value obtained in each step in the table .

Order #	V_D (V)	I_D (mA)
1	0	
2	4.0	
3	8.0	
4	12.0	

EEE353 Experiment 1c: EXAMINATION OF ZENER DIODE

List of Materials

- Adjustable Power Supply (DC)
- Voltage Meter (DC)
- Current Meter (DC)
- Zener Diode (1N4738, 8.2V, 1W Zener)
- Resistance (330Ω)

HOW TO DO THE EXPERIMENT: Make the circuit connections as shown in the Figure.

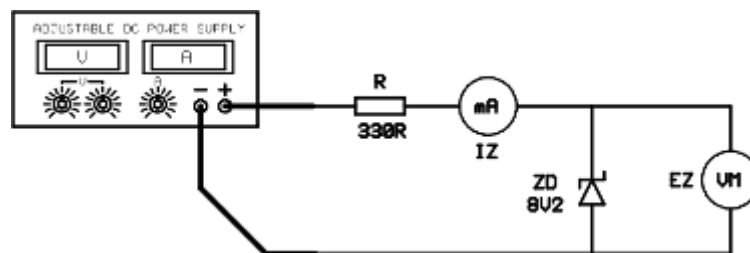

Figure 1

Set the voltage potentiometers of the regulated power supply to zero.

Apply power to the circuit.

Answer the questions.

1- How is the Zener diode polarized? Why?

2- Adjust the voltage of the regulated power supply to the values in Table 1. Record the current (I_Z) and voltage (V_Z) of the zener diode in each step.

Table 1

Order #	Power Supply (V)	V_Z (V)	I_Z (mA)
1	0		
2	2.0		
3	5.0		
4	8.0		
5	8.1		
6	8.2		
7	8.3		
8	8.4		
9	8.5		
10	9.0		

3- At what voltage did the current of the Zener diode suddenly increase? What does this mean?

4- Draw the reverse polarization characteristics of the zener diode according to the values in Table 1.

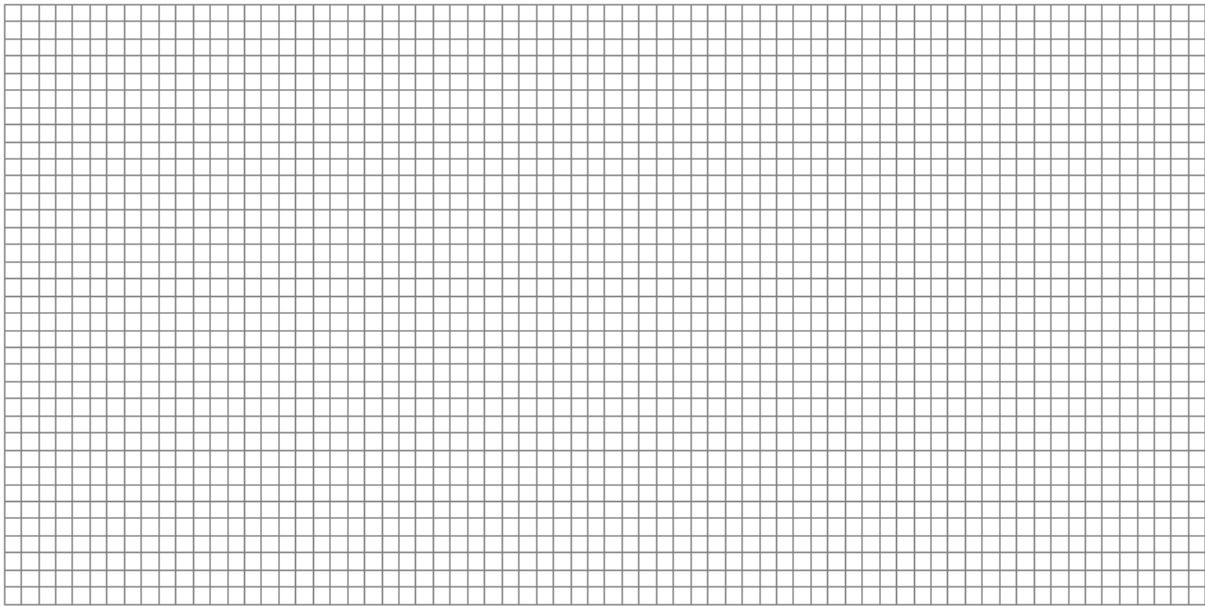

5- What would be the correct direction characteristic if the Zener diode was correctly polarized? Also show the correct direction characteristic.

