



EEE238 CIRCUIT THEORY II EXPERIMENT 2

Dr. Öğr. Abbas Uğurenver

Istanbul Aydın University

Engineering Faculty, Electrical and Electronics Department

Experiment 2

Op Amp: AC Applications

PURPOSE OF THE EXPERIMENT:

The objective of this experiment is to conduct practical circuit studies to better understand the amplifier feature of the operational amplifier (op-amp) in AC circuits and signals.

A. TO BE USED VEHICLE AND MATERIALS:

1. Signal generator
2. Oscilloscope
3. 741 IC, resistors of various values, and connecting cables
4. Protoboard

B. EXPERIMENT STEPS:

1. Below given circuit eyelash before take it. 741 for dc supply voltage: $V_+ = 20V$, $V_- = -20V$

This circuit for the following seven different situation in sight take it.

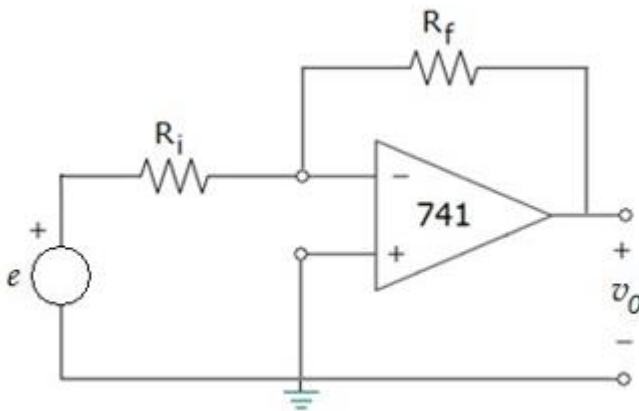

- a) $e = 1.2\sin 6280t$, $R_i = 1.5 \text{ k}\Omega$, $R_f = 1.5 \text{ k}\Omega$
- b) $e = 1.2\sin 6280t$, $R_i = 1.5 \text{ k}\Omega$, $R_f = 3 \text{ k}\Omega$
- c) $e = 1.2\sin 6280t$, $R_i = 3 \text{ k}\Omega$, $R_f = 1.5 \text{ k}\Omega$
- d) $e = 1V-1.5\text{kHz}$ square wave, $R_i = 1.5 \text{ k}\Omega$, $R_f = 3 \text{ k}\Omega$
- e) $e = 1V-1.5\text{kHz}$ square wave, $R_i = 3 \text{ k}\Omega$, $R_f = 1.5 \text{ k}\Omega$
- f) $e = 1.5V-2\text{kHz}$ triangle wave, $R_i = 1.5 \text{ k}\Omega$, $R_f = 3 \text{ k}\Omega$
- g) $e = 1.5V-2\text{kHz}$ triangle wave, $R_i = 3 \text{ k}\Omega$, $R_f = 3 \text{ k}\Omega$

Calculation Steps: Above given seven situation for v_0 exit voltages separate Calculate separately and record in Table 1.

	v_0		v_0
a		e	
b		f	
c		g	
d			

- Measuring Steps:

Build the circuit on the protoboard. For the seven cases given above, v_0 measure the output voltages with an oscilloscope and plot the results.

Note: When plotting the results: 1. Before plotting, mark take it to its widest position horizontally and vertically on the screen. For this, volts/div, time/div, right-left use the scroll keys. 2. draw to scale.

a) $e = \dots\dots\dots$, $R_i = \dots\dots\dots$, $R_f = \dots\dots\dots$

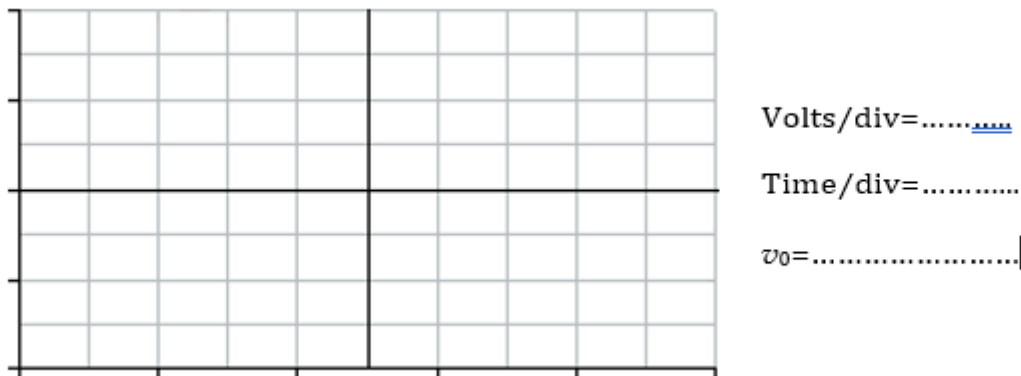

b) $\underline{g} = \dots\dots\dots$, $R_i = \dots\dots\dots$, $R_f = \dots\dots\dots$

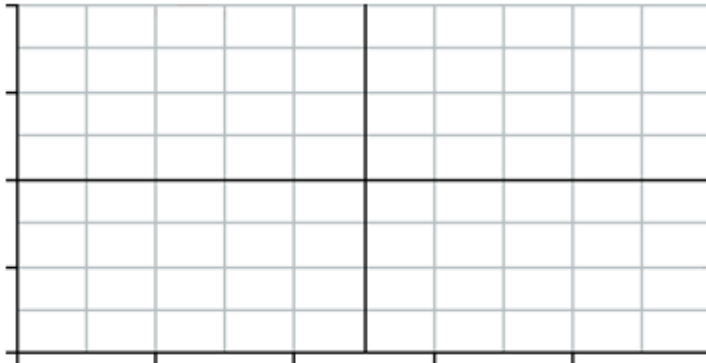

Volts/div =

Time/div =

$v_0 = \dots\dots\dots$

c) $\underline{g} = \dots\dots\dots$, $R_i = \dots\dots\dots$, $R_f = \dots\dots\dots$

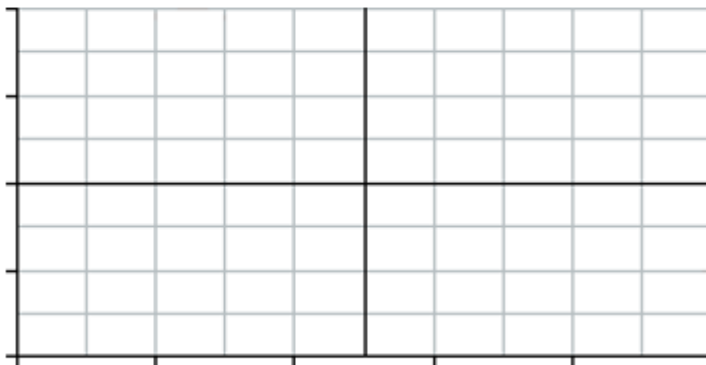

Volts/div =

Time/div =

$v_0 = \dots\dots\dots$

d) $\underline{g} = \dots\dots\dots$, $R_i = \dots\dots\dots$, $R_f = \dots\dots\dots$

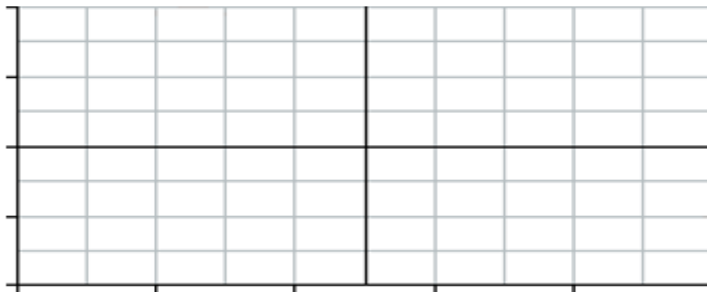

Volts/div =

Time/div =

$v_0 = \dots\dots\dots$

e) $\underline{g} = \dots\dots\dots$, $R_i = \dots\dots\dots$, $R_f = \dots\dots\dots$

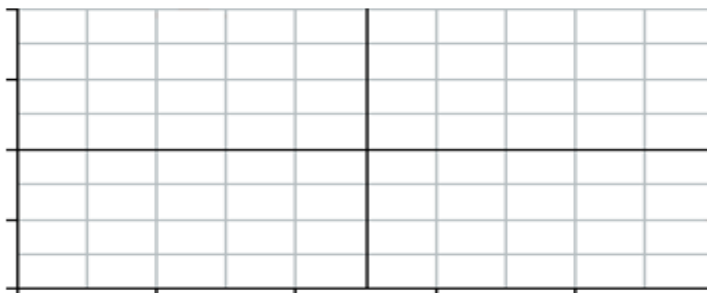

Volts/div =

Time/div =

$v_0 = \dots\dots\dots$

f) $\underline{e} = \dots\dots\dots$, $R_i = \dots\dots\dots$, $R_f = \dots\dots\dots$

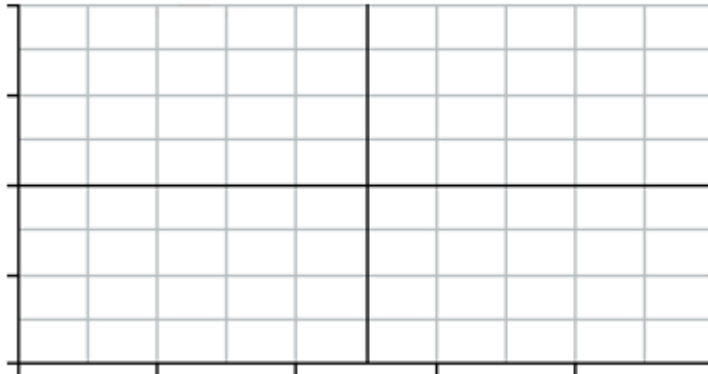

Volts/div =

Time/div =

$v_0 = \dots\dots\dots$

g) $\underline{e} = \dots\dots\dots$, $R_i = \dots\dots\dots$, $R_f = \dots\dots\dots$

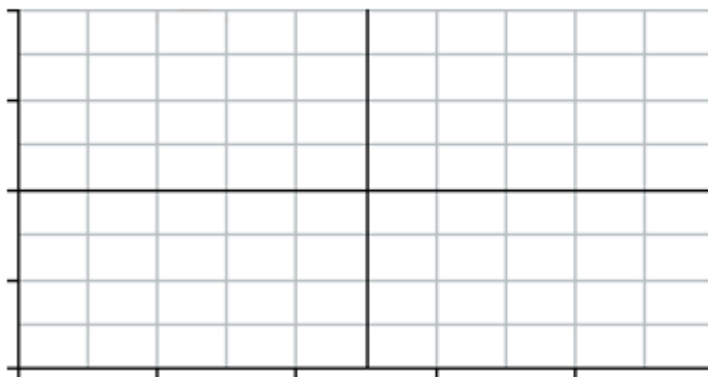

Volts/div =

Time/div =

$v_0 = \dots\dots\dots$